

# M140TG

## 14" Intel® Core™ i5-1135G7 Windows Rugged Tablet



### KEY FEATURES

- 11th Gen. Intel® Processor Family – Tiger Lake Processor
- 14-inch tablet, 1920 x 1080 wide viewing angle LED Panel
- Optical bonding and Antiglare technology for sunlight readability
- IP65 waterproof and dustproof
- Hot-swappable battery for whole day work
- Optional integrated Smart Card Reader



### SPECIFICATIONS

Display			
<b>Bonding</b>	Optical Bonding for Sunlight Viewability	<b>Resolution</b>	1920x1080
<b>Size</b>	14.0 inches	<b>Contrast Ratio</b>	800:1
<b>Panel Brightness</b>	700.0 nits	<b>View Angles</b>	85,85,85,85
<b>Type</b>	Projected Capacitive Multi Touch		
System Specification			
<b>Processor</b>	Intel Core i5-1135G7 2.4GHz (up to 4.2GHz)	<b>Memory</b>	4GB DDR4 SDRAM 8GB DDR4 SDRAM (Optional) 16GB DDR4 SDRAM (Optional) 32GB DDR4 SDRAM (Optional)
<b>Storage</b>	128GB SSD Additional storage available with micro SDXC card slot 256GB SSD (Optional) 512GB SSD (Optional) 1TB SSD (Optional) 2TB SSD (Optional)	<b>Ethernet controller</b>	1 x RJ45-10/100/1000 Mbps LAN
<b>Security</b>	Trusted Platform Module (TPM) 2.0 Kensington Lock	<b>Operating System</b>	Windows 10 IoT Enterprise (64 bit)
<b>WLAN</b>	Support	<b>BT</b>	Support
<b>WWAN</b>	4G LTE (Optional)	<b>GNSS</b>	GPS, GLONASS (Optional)
<b>RFID</b>	HF RFID reader 13.56 MHz (Optional)	<b>Sensors</b>	Light sensor/ G-sensor / Gyro
<b>Smart Card Reader</b>	Smart Card Reader Comply with ISO7816-1.2.3 T=1 and T=Ø protocol (Optional)		
Camera			
<b>Front Camera</b>	2MP Front Camera	<b>Rear Camera</b>	8MP Rear Camera with auto-focus and LED light
Mechanical			
<b>Dimension</b>	341.91 x 224.67 x 25.4 mm	<b>Weight</b>	1.7 kg
<b>Cooling System</b>	Fan design		
IO Ports			
<b>USB Port</b>	2 x USB 3.0 (Type A), 1 x USB 3.0 (Type C)	<b>SD Card Slot</b>	1 x Micro SDXC slot
<b>SIM Card Slot</b>	1 x Nano SIM card slot	<b>Video</b>	1 x Micro HDMI (Optional)

<b>Audio</b>	1 x Audio combo 3.5mm audio combo jack Dual Digital Mic With Noise Cancellation Dual Speaker	<b>LAN</b>	1 x RJ45-10/100/1000 GigaLAN port
<b>Indicator</b>	4x LED Indicator for Power, Battery, HDD, RF status		
<b>Environment</b>			
<b>Operating Humidity</b>	10% to 90% RH, non-condensing	<b>Operating Temperature</b>	-20°C to 60°C (AC mode), -10°C to 50°C (Battery mode)
<b>Storage Temperature</b>	-30°C to 70°C (-22°F to 158°F)	<b>Shock</b>	MIL-STD-810H Method 516.8 Procedure I
<b>Vibration</b>	MIL-STD-810H Method 514.8 Procedure I	<b>IP rating</b>	IP65
<b>Drop</b>	MIL-STD-810H Method 516.8, 4 ft		
<b>Certification</b>			
<b>Certification</b>	CE, FCC		
<b>Security Function</b>			
<b>SOTI MobiControl</b>	SOTI MobiControl Compliance	<b>Kensington Lock</b>	Kensington Lock Support
<b>Control</b>			
<b>Button</b>	1 x Power, 3 x function keys		
<b>Power</b>			
<b>Battery</b>	Internal Battery: 10.8V typ. 2400 mAh Li-Ion Battery Hot-swappable 11.4V, typ. 3500 mAh Li-Ion Rechargeable Battery (3S1P)	<b>Power Rating</b>	19V DC
<b>Adapter</b>	100-240V, 50-60Hz / 19V DC		
<b>Accessory</b>			
<b>Accessory</b>	Adapter and Power Cord Standard Battery Capacitive Stylus	<b>Optional Accessory</b>	Kickstand (Optional) Vehicle Charger (Optional) Battery Charger (Optional) Shoulder Strap (Optional) Carry Bag (Optional)
<b>Barcode Scanner</b>			

## DIMENSIONS UNIT:MM

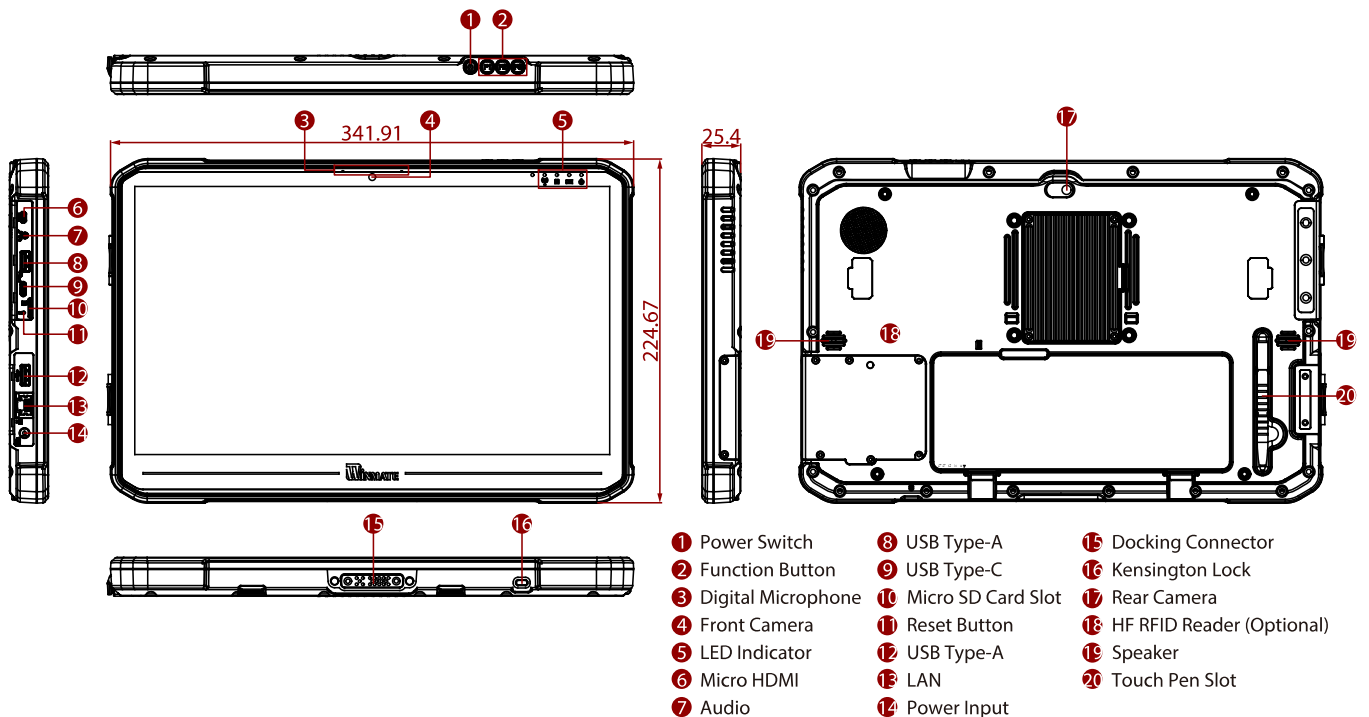

## NOTE

1. This is a simplified drawing and some components are not marked in detail.
2. Please contact our sales representative if you need further product information.
3. All specifications are subject to change without prior notice.
4. The product shown in this datasheet is a standard model. For diagrams that contain customized or optional I/O, please contact the Winmate Sales Team for more information.

**g Connector** 1 x 19-pin docking connector